

# AUDREY 2

pendant | user guide

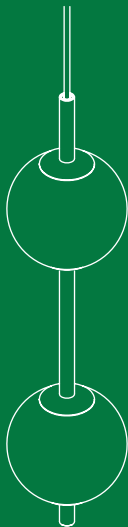

UIMAGE



## WITH LOVE FROM COPENHAGEN

At UIMAGE, our designers take inspiration from the distinct nature of the Nordic landscape to create unique designs related to the way we live in an urban setting. Influenced by the design language, colours and materials found around us in Scandinavia, we create a collection that is rooted in our home but designed for everyone.



## **ENGLISH**

**IMPORTANT!** Always shut off the power to the circuit before starting installation work. In some countries, electrical installation work may only be carried out by an authorised electrical contractor. Contact your local electricity authority for advice.

Different wall materials require different types of screws. Always choose screws that are specially suited to the materials of your walls.

The light source contained in this luminaire shall only be replaced by the manufacturer or his service agent or a similar qualified person.

## **DEUTSCH**

**WICHTIG!** Vor der Installation den Strom abschalten. In einigen Ländern dürfen Elektroinstallationen nur von autorisierten Elektrofachleuten ausgeführt werden. Im Zweifelsfall

die örtlichen Behörden ansprechen.

Unterschiedliche Wandmaterialien erfordern unterschiedliche Schrauben. Immer Schrauben verwenden, die für die Wandbeschaffenheit geeignet sind.

Die in dieser Leuchte enthaltene Lichtquelle darf nur durch den Hersteller, durch seinen Kundendienst oder eine ähnlich qualifizierte Person ersetzt werden.

## **FRANÇAIS**

**ATTENTION!** Toujours couper l'alimentation au panneau principal avant de procéder à l'installation. Dans certains pays, l'installation doit être effectuée par un électricien qualifié. Pour en savoir plus, contacter les autorités locales compétentes en la matière.

Le choix des vis dépend du matériau dans lequel elles doivent être fixées.

Utiliser des vis adaptées au matériau de votre mur.

La source lumineuse présente dans ce luminaire ne doit être remplacée que par le fabricant, son prestataire de services ou une personne qualifiée similaire.

### **NEDERLANDS**

**BELANGRIJK!** Schakel de stroom altijd uit voordat met de installatie wordt begonnen. In sommige landen mogen elektrische installaties alleen worden uitgevoerd door een bevoegd electricien. Neem daarom contact op met de plaatselijke overheid voor advies.

Voor verschillende wandmaterialen heb je verschillende schroeven nodig. Completeer met schroeven die geschikt zijn voor het materiaal van de wand.

De lichtbron in deze armatuur mag

alleen worden vervangen door de fabrikant of zijn servicevertegenwoordiger of een gelijkaardig gekwalificeerd persoon.

### **DANSK**

**VIGTIGT!** Sluk altid for strømmen, før installationen påbegyndes. I nogle lande må elektriske installationer kun udføres af en uddannet elektriker. Få oplysninger hos de relevante myndigheder.

Forskellige vægmateriale kræver forskellige typer skruer. Vælg skruer, som egner sig til det relevante vægmateriale.

Lyskilden i dette armatur må kun udskiftes af producenten eller dennes servicerepræsentant eller en tilsvarende kvalificeret person.

### **ÍSLENSKA**

**MIKILVÆGT!** Sláið rafmagnið úr áður

en uppsetning hefst. Í sumum löndum þarf uppsetning að vera framkvæmd af löggiltum rafvirkja. Leitið ráða hjá rafvirkja varðandi uppsetninguna.

Veggir húsa eru úr mismunandi efnum og nota þarf mismunandi skrúfur í þá. Veljið alltaf skrúfur sem henta efninu í veggjum heimilisins.

Framleiðandi, þjónustuaðili eða annar sambærilegur aðili með fullgilda hæfni ætti aðeins að skipta um ljósgjafann í þessari lýsingu.

## **NORSK**

VIKTIG! Elektriske installasjoner skal utføres av elektriker.

Ulike veggmaterialer krever ulike skruer. Suppler med skruer som passer til materialet i din vegg.

Lyskilden i dette armaturet skal kun byttes av produsenten, produsentens

servicerepresentant eller en autorisert elektriker.

## **SUOMI**

TÄRKEÄÄ! Katkaise aina virta pääkatkaisimestra ennen asennusta. Joissakin maissa kytkennän saa tehdä vain ammattitaitoinen sähköasentaja. Selvitä paikalliset määräykset.

Erilaisiin seinämateriaaleihin on käytettävä erilaisia ruuveja. Valitse kotisi seinämateriaaliin sopivat ruuvit.

Ainoastaan valmistaja tai valmistajan valtuuttaman huoltoliikkeen edustaja tai vastaava pätevä henkilö saa vaihtaa tämän valaisimen sisältämän valonlähteen.

## **SVENSKA**

VIKTIGT! Stäng alltid av strömmen innan installation påbörjas. I vissa länder får elektrisk installation endast utföras av auktoriserad elektriker.

Kontakta din lokala myndighet för råd.

Olika väggmaterial kräver olika skruvar. Komplettera med skruvar som passar materialet i din vägg.

Ljuskällan i denna armatur får endast bytas ut av tillverkaren, dennes serviceombud eller en liknande kvalificerad person.

## ČESKY

**DŮLEŽITÉ!** Před instalací vždy odpojte ze sítě. V některých zemích může instalaci provést pouze kvalifikovaný elektrikář. Kontaktujte o radu nejbližšího elektrikáře.

Různé typy stěn vyžadují různé druhy šroubů. Vždy použijte šrouby, které jsou vhodné do daného typu materiálu.

Světelný zdroj obsažený v tomto

svítidle smí vyměnit pouze výrobce nebo jeho servisní zástupce nebo podobná kvalifikovaná osoba.

## ESPAÑOL

**IMPORTANTE!** Desconecta siempre el interruptor general de la electricidad antes de iniciar cualquier trabajo de instalación. En algunos países, la instalación eléctrica sólo puede realizarla un electricista profesional. Ponte en contacto con las autoridades locales para saber cuál es tu caso.

Diferentes materiales de pared requieren diferentes tornillos. Completa con aquellos que mejor se adapten a tu tipo de pared.

La fuente de luz contenida en esta luminaria solo debe ser reemplazada por el fabricante o su agente de servicio o una persona con calificaciones similares.



## ITALIANO

**IMPORTANTE!** Togli sempre tensione al circuito prima di iniziare l'installazione. In alcune nazioni l'installazione elettrica può essere effettuata solo da un elettricista autorizzato. Per maggiori informazioni, contatta l'autorità locale per l'energia elettrica.

I diversi materiali delle pareti richiedono tipi diversi di viti. Scegli viti adatte al materiale della parete in questione.

La sorgente luminosa contenuta in questa lampada deve essere sostituita solo dal produttore o dal suo agente di servizio o da una persona qualificata simile.

## MAGYAR

**FONTOS!** Minden esetben kapcsolod le az áramot mielőtt elkezded a munkát. Néhány országban elektromos installációt kizárólag

szakember végezhet. Ezzel kapcsolatban érdeklődj elektromos szolgáltatódnál.

A különböző anyagú falakhoz, különböző típusú csavarokat használj. Válassz mindig olyan csavart (és tipliket), melyek a leginkább alkalmasak a falad anyagához.

A lámpatestben található fényforrás kicserélésére csak a gyártó, a gyártó által megbízott szerviz vagy szakképzett személy jogosult.

## POLSKI

**WAŻNE!** Przed rozpoczęciem instalacji odłącz zasilanie. W niektórych państwach instalacje elektryczne mogą być wykonywane wyłącznie przez wykwalifikowanych elektryków. Skontaktuj się z odpowiednimi instytucjami, aby uzyskać poradę.

Do różnego rodzaju ścian pasują różne rodzaje wkretów. Wybieraj zawsze wkrety odpowiednie do Twoich ścian.

Źródło światła zawarte w tej oprawie oświetleniowej może być wymiennie wyłączanie przez producenta, jego przedstawiciela serwisowego lub inną osobę o podobnych kwalifikacjach.

## EESTI

OLULINE! Lülitage alati enne paigaldustööde alustamist elekter välja. Mõnes riigis võib elektritööd teostada ainult litsentseeritud elektrik. Võtke ühendust kohaliku elektriteenust pakkuva asutusega.

Erinevatel seinte materjalidel kasutatakse erinevaid kruvisid. Valige ja kasutage alati kruvisid, mis sobivad spetsiaalselt teie seintele.

Selle valgusti valgusallikat tohib vahetada ainult tootja, tootja esindaja või mõni teine sama pädevusega isik.

## LATVIEŠU

SVARĪGI! Pirms montāžas darbu uzsākšanas vienmēr atvienojiet galveno strāvas padevi. Dažās valstīs elektroinstalācijas darbus drīkst veikt tikai sertificēts elektriks. Neskaitrību gadījumā sazinieties ar savu vietējo energoapgādes uzņēmumu.

Skrūves jāizvēlas atkarībā no sienu materiāla. Vienmēr izvēlieties skrūves, kas ir piemērotas konkrētajam sienu materiālam.

Šajā gaismeklī esošo gaismas avotu drīkst nomainīt tikai ražotājs vai tā servisa pārstāvis vai līdzīga kvalificēta persona.

## LIETUVIŲ

SVARBU! Prieš pradėdami elektros

instalações de trabalho, visada a desinstalar a energia elétrica. Quando necessário, as instalações de trabalho podem ser realizadas por um electricista autorizado. Contacte a sua autoridade local de electricidade para aconselhamento.

Para diferentes tipos de paredes, são necessários diferentes tipos de parafusos. Escolha sempre parafusos adequados aos materiais das suas paredes.

A fonte de luz contida nesta luminária pode ser substituída apenas pelo fabricante ou pelo seu agente encarregado ou outra pessoa qualificada.

## **PORTUGUÊS**

**IMPORTANTE** Desligue sempre a corrente eléctrica antes de começar um trabalho de instalação. Em alguns

países os trabalhos de instalação eléctrica só podem ser realizados por um electricista autorizado. Contacte a sua autoridade local de electricidade para aconselhamento.

Os diferentes materiais de parede requerem diferentes tipos de parafusos. Escolha sempre parafusos adequados aos materiais das suas paredes.

A fonte de luz contida nesta luminária pode ser substituída apenas pelo fabricante ou pelo seu agente encarregado ou outra pessoa qualificada.

## **ROMÂNIA**

**ATENȚIE!** Opriți întotdeauna alimentarea cu curent electric înainte de a începe lucrările de instalare. În unele țări, operațiunile de instalare pot fi efectuate numai de către un instalator autorizat. Pentru mai multe informații, contactați

autoritatea locală care gestionează energia electrică.

Materialele variate din care sunt construiți pereții necesită diferite tipuri de șuruburi. Alege întotdeauna șuruburi adecvate materialelor pereților tăi.

Sursa de iluminare conținută în acest corp de iluminat trebuie înlocuită numai de către producător, angajat al unui service sau de o persoană calificată similar.

## SLOVENSKY

**DÔLEŽITÉ!** Pred inštaláciou vždy odpojte zo siete. Zistite si, či nepatrí- te medzi tie krajiny, kde inštaláciu môže uskutočniť výlučne elektrikár. O radu požiadajte vašu lokálnu autoritu.

Rôzne typy stien vyžadujú rôzne typy skrutiek. Vždy použite skrutky

vhodné do daného materiálu.

Svetelný zdroj obsiahnutý v tomto svietidle môže vymeniť iba výrobca alebo jeho servisný zástupca alebo podobne kvalifikovaná osoba.

## БЪЛГАРСКИ

**ВАЖНО!** Винаги изключвайте електрозахранването във веригата, преди да извършвате работа по инсталацията. В някои страни работа по електрическите инсталации може да се извършва единствено от оторизиран електротехник. За препоръка се обърнете към местната електрическа компания.

Различните стени материали изискват различни видове винтове. Винаги избирайте винтове, специално съобразени с материала на вашите стени.

Източникът на светлина, съдържащ се в това осветително тяло може да се замени само от производителя или от гаранционен сервиз или друго такова компетентно лице.

#### HRVATSKI

VAŽNO! Uvijek isključite struju prije instalacije. U nekim zemljama postavljanje električnih instalacija može obavljati samo ovlašteni električar. Za savjet kontaktirajte svog lokalnog ovlaštenog električara.

Različite vrste vijaka koriste se za različite vrste zidova. Uvijek odaberite vijke koji točno odgovaraju vrsti vaših zidova.

Izvor svjetlosti u ovoj svjetiljci smije zamijeniti samo proizvođač ili njegov servis ili slična kvalificirana osoba.

#### ΕΛΛΗΝΙΚΑ

ΣΗΜΑΝΤΙΚΟ! Πριν από την έναρξη της εργασίας εγκατάστασης, να διακόπτετε πάντα την παροχή ρεύματος από τον γενικό διακόπτη. Σε μερικές χώρες, οι ηλεκτρολογικές εργασίες θα πρέπει να πραγματοποιούνται μόνο από ένα εξουσιοδοτημένο ηλεκτρολόγο. Για πληροφορίες, επικοινωνήστε με την εταιρία ηλεκτρισμού της περιοχής σας.

Για τα διαφορετικά υλικά τοίχου, απαιτούνται και διαφορετικοί τύποι βιδών. Επιλέγεται πάντοτε βίδες, οι οποίες να είναι ειδικά κατάλληλες για τα υλικά των τοίχων σας.

Η πηγή φωτός που περιλαμβάνεται σε αυτό το φωτιστικό θα πρέπει να αντικαθίσταται μόνο από τον κατασκευαστή ή τον επισκευαστή συνεργάτη του ή παρόμοιο πιστοποιημένο άτομο.

## РУССКИЙ

**ВНИМАНИЕ!** Перед установкой всегда отключайте электропитание. В некоторых странах электроустановка должна производиться только квалифицированным электриком. Обратитесь за консультацией в соответствующие местные инстанции.

Для различного типа стен требуются различные виды шурупов. Всегда выбирайте шурупы, которые подходят к материалу Ваших стен.

Источник света, содержащийся в этом светильнике, может быть заменен только производителем, его агентом по обслуживанию или аналогичным квалифицированным лицом.

## SRPSKI

**BITNO!** Uvek isključite struju pre nego što počnete s intaliranjem. U pojedinim državama elektroinstalacije mogu da postave samo osobe s ovlašćenjem. Obratite se lokalnoj elektro-distribuciji za savet.

Različite vrste zidova zahtevaju različite tiplove. Uvek odaberite tiplove koji odgovaraju vrsti vašeg zida.

Izvor svetlosti koji se nalazi u ovoj svetiljci može da zameni samo proizvođač ili njegov serviser ili slična kvalifikovana osoba.

## SLOVENŠČINA

**POMEMBNO!** Pred začetkom dela vedno izklopite električno napajanje. V nekaterih državah sme električno napeljavo napeljevati le pooblaščeni električar. Za nasvet se obrnite na najbližji pooblaščeni servis.

Različni stenski materiali zahtevajo različne vrste vijakov. Vedno uporabite takšne vijake, ki ustrezajo sestavi vaše stene.

Svetlobni vir, ki ga vsebuje ta svetilka, sme zamenjati samo proizvajalec ali njegov serviser ali podobna usposobljena oseba.

## TÜRKÇE

**ÖNEMLİ!** Kurulumu başlamadan önce her zaman elektrik devresini kapatınız. Bazı ülkelerde elektrik kurulum işlemi sadece yetkili elektrik teknikerleri tarafından yapılmaktadır. Size en yakın yerel elektrik idaresi ile temas kurarak bu konuda bilgi alabilirsiniz.

Farklı duvar materyalleri farklı türde vida gerektirir. Her zaman, duvarınızın yapı malzemesine uygun vidaları seçiniz.

Bu lambada bulunan ışık kaynağı yalnızca üretici veya servis sorumlusu ya da benzer vasıflı kişi tarafından değiştirilmelidir.

## **BAHASA INDONESIA**

**PENTING!** Selalu matikan listrik ke sirkuit sebelum memulai pekerjaan pemasangan. Di beberapa negara pekerjaan pemasangan listrik hanya boleh dilakukan oleh tukang listrik tersertifikasi. Hubungi tukang listrik berwenang di tempat anda untuk saran.

Untuk bahan dinding yang berbeda membutuhkan jenis sekrup yang berbeda. Selalu memilih sekrup yang sesuai untuk bahan dinding Anda.

Sumber cahaya yang terdapat dalam lumener ini hanya boleh diganti oleh pabrikan, agen servis resmi atau orang yang memiliki kualifikasi.

## BAHASA MALAYSIA

PENTING! Sentiasa padamkan bekalan kuasa ke litar sebelum memulakan kerja-kerja pemasangan. Di beberapa negara kerja-kerja pemasangan elektrik hanya boleh dilakukan oleh kontraktor elektrik yang bertauliah. Hubungi pihak berkuasa tempatan untuk mendapatkan nasihat tentang bekalan elektrik.

Bahan dinding yang berlainan memerlukan jenis skru yang berlainan. Sentiasa pilih skru yang paling sesuai dengan bahan binaan bagi dinding anda.

Peralatan cahaya yang ada dalam lampu ini hanya boleh ditukar oleh pengeluar atau ejen perkhidmatan dan orang yang mempunyai kelayakan yang setaraf.

한국어

중요! 설치작업을 시작하기 전 반드시

회로의 전원을 차단하세요. 일부 국가에 서는 공인전기시공업체만 전기 공사를 진행할 수 있습니다. 관련 정보는 지역 전력 관할 기관에 문의하세요.

벽에 따라 다른 종류의 나사를 사용해야 합니다. 반드시 벽에 적합한 나사를 사용하세요.

이 조명기구에 포함된 광원은 제조업체, 서비스 업체 또는 이와 유사한 사업자들만 교체 할 수 있다.

日本語

重要 設置作業を開始する前に必ずブレーカーを切ってください。電気工事の作業を行うには、資格を必要とする国もあります。お近くの電気工事店にご相談ください。

器具を固定するためのネジは壁の材質により異なります。必ず壁の材質に合ったネジを使用してください。



この照明器具に含まれている光源は、製造者、そのサービス代理店、または同様の資格を持つ人によってのみ交換されるものとします。

中文

重要事项 安装工作开始前，请务必切断电路电源。在一些国家，电气安装必须由有资质的电力承包商完成。请联系您当地的电力部门，征询建议。

不同的安装面材需采用不同种类的安装螺钉。根据墙体材料，选择适用的安装五金件。

本灯具内的光源只能由制造商或其服务代理或具有相关资格的人员更换

繁中

重要訊息 安裝前請務必關掉電源。有些國家的電力安裝工作需由有執照的專業電工執行，如有任何疑問，請聯絡專業人員。

請選購適合貴戶牆壁材質的螺絲配件

本燈具內的光源只能由製造商或其服務代理或具有相關資格的人員更換。



Points de collecte sur [www.quefairedemesdechets.fr](http://www.quefairedemesdechets.fr)  
Privilégiez la réparation ou le don de votre appareil !



DESIGNED BY  
SØREN RAVN CHRISTENSEN

“Capturing the essence of a true icon, Audrey is a luminary creation, adorning your space with radiant pearls of illumination.”

# ASSEMBLY GUIDE

① × 1 pc.

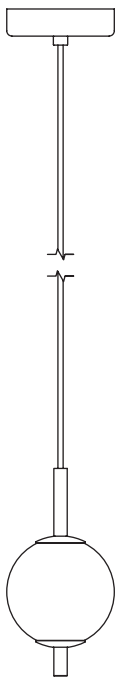

② × 2 pcs.



③ × 1 pc.

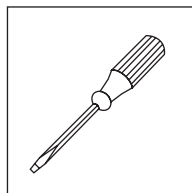
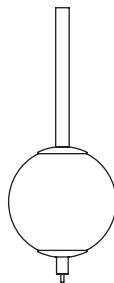

## ENGLISH

This product contains light sources of energy efficiency class D.

## DEUTSCH

Dieses Produkt enthält Lichtquellen der Energieeffizienzklasse D.

## FRANÇAIS

Ce produit contient source lumineuses de classe d'efficacité énergétique D.

## NEDERLANDS

Dit product bevat lichtbronnen van energie-efficiëntieklasse D.

## DANSK

Denne produkt indeholder lyskilder i energieeffektivitetsklasse D.

## SUOMI

Tämä tuote sisältää valonlähteet, jonka energiatehokkuusluokka on D.

## SVENSKA

Denna produkt innehåller ljuskällor med energieffektivitetsklass D.

## ČESKY

Tento výrobek obsahuje světelné zdroje s třídou energetické účinnosti D.

## ESPAÑOL

Este producto contiene fuentes de luz de la clase de eficiencia energética D.

## ITALIANO

Questo prodotto contiene sorgenti luminose di classe di efficienza energetica D.

## MAGYAR MALTI

Ez a termék D energiahatékonysági osztályú fényforrásokat tartalmaz.

## MALTI

Dan il-prodott fih sorsi tad-dawl bi klassi ta' effiċjenza enerġetika D.

## PORTUGUÊS

Este produto contém fontes de luz com classe de eficiência energética D.

## EESTI

See toode sisaldab D-energiatõhusus klassiga valgusallikaid.

## POLSKI

W tym produkcji znajdują się źródła światła o klasie efektywności energetycznej D.

## LATVIEŠU

Šajā produktā ir gaismas avoti ar D enerģoefektivitātes klasi.

## LIETUVIŲ

Šiame gaminyje yra šviesos šaltiniai, kurių energijos vartojimo efektyvumo klasė yra D.

## ROMÂNĂ

Acest produs conține surse de lumină cu clasa de eficiență energetică D.

## SLOVENSKY

Tento výrobok obsahuje svetelné zdroje s energetickou triedou D.

## БЪЛГАРСКИ

Този продукт съдържа източници на светлина с енергийна ефективност клас D.

## HRVATSKI

Ovaj proizvod sadrži izvore svjetlosti energetske učinkovitosti klase D.

## ΕΛΛΗΝΙΚΑ

Αυτό το προϊόν περιέχει πηγές φωτός κλάσης ενεργειακής απόδοσης D.

## SLOVENŠČINA

Ta izdelek vsebuje svetlobne vire energijskega razreda D.

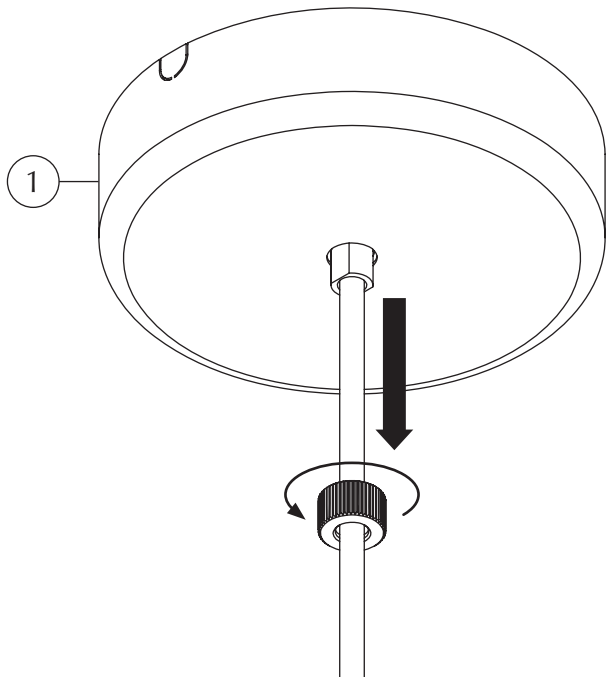

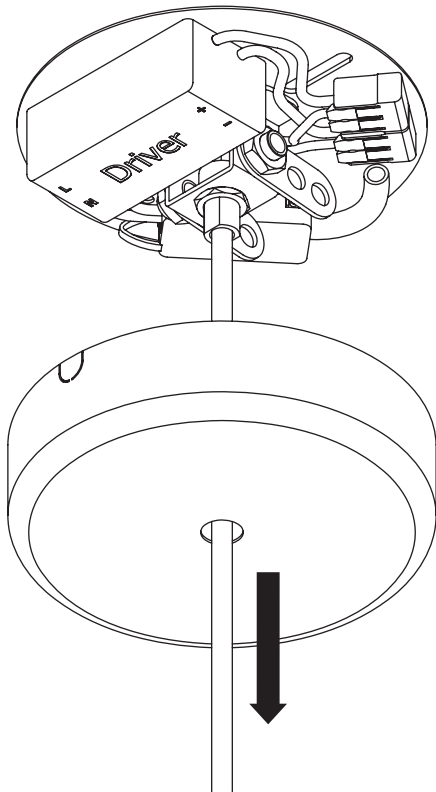

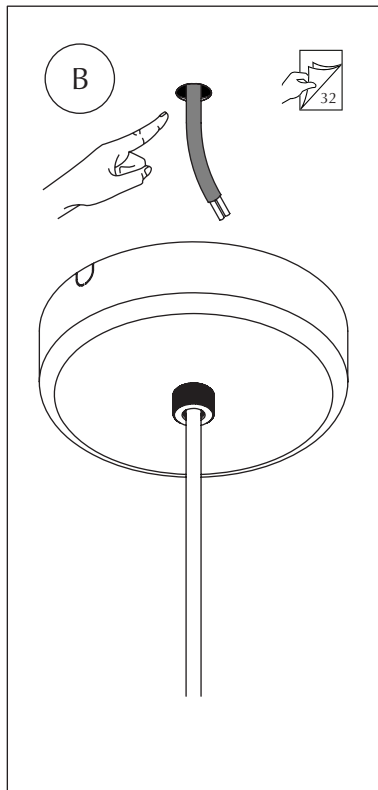
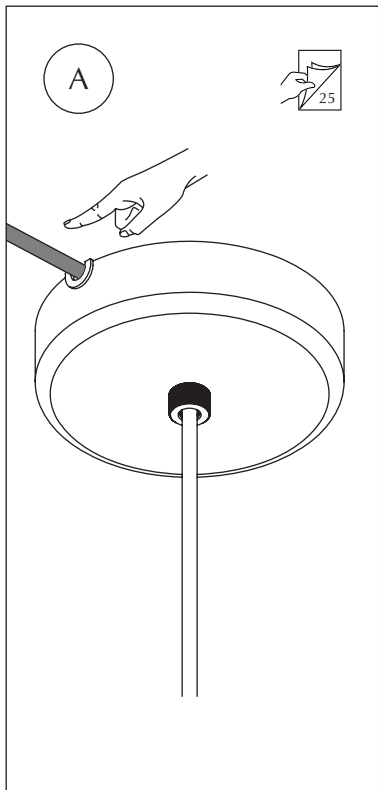



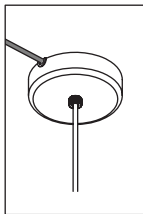

A.1

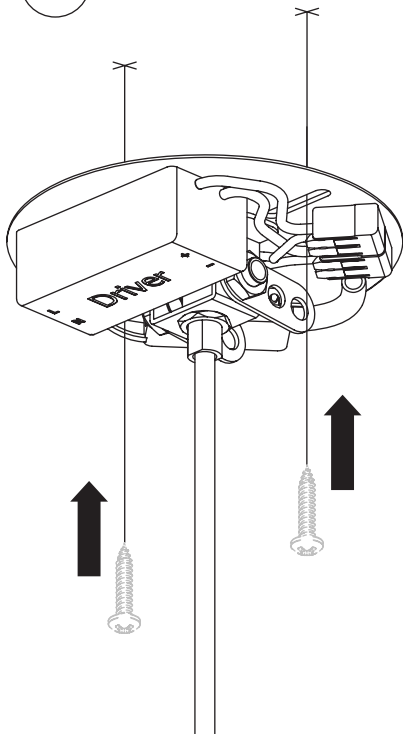
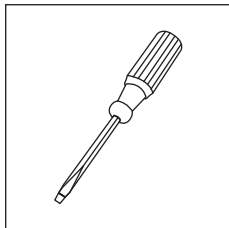

A.2

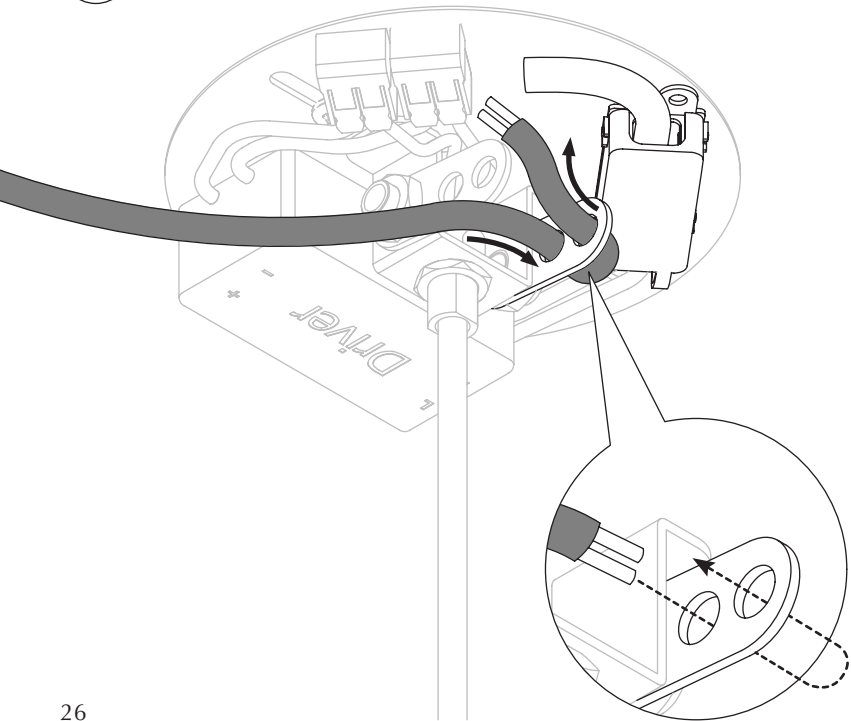

A.3

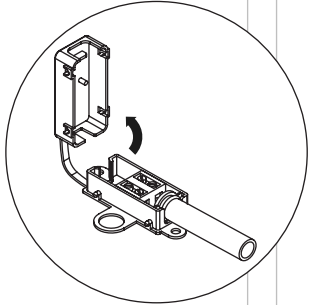
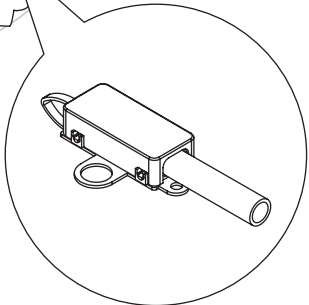
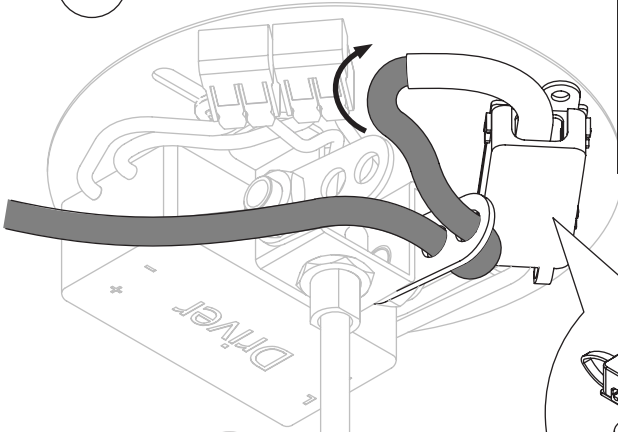
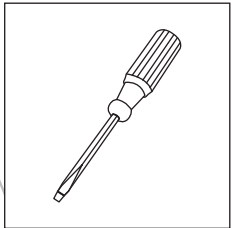

A.4

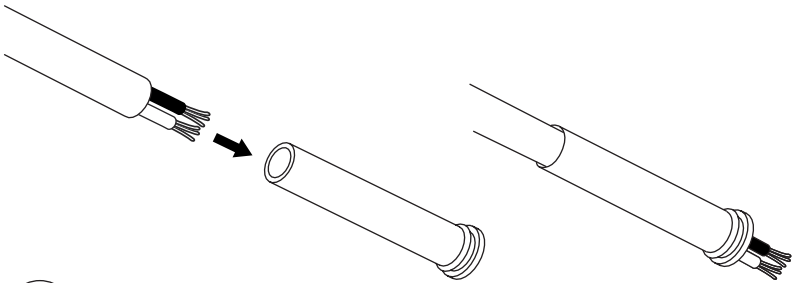

A.5

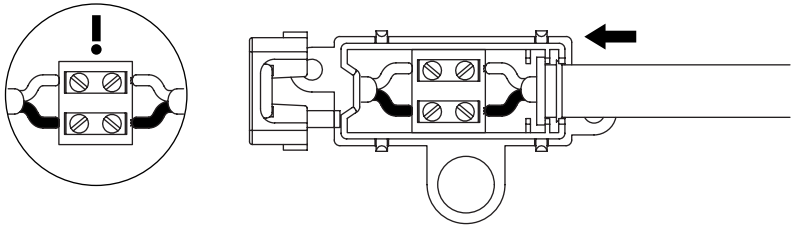

A.6

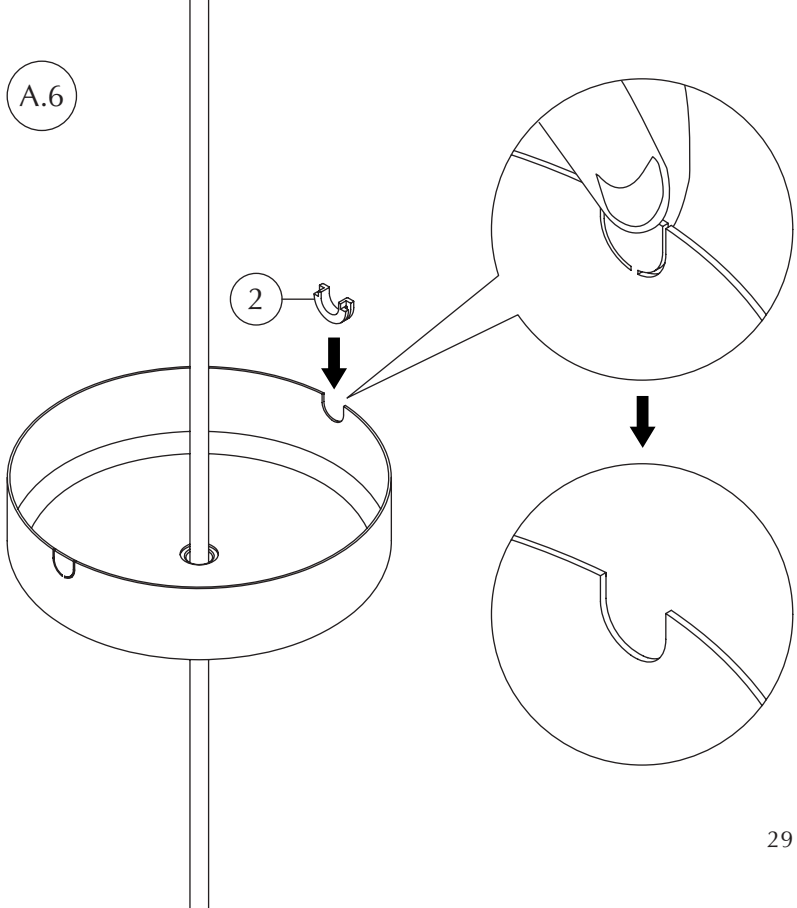

A.7

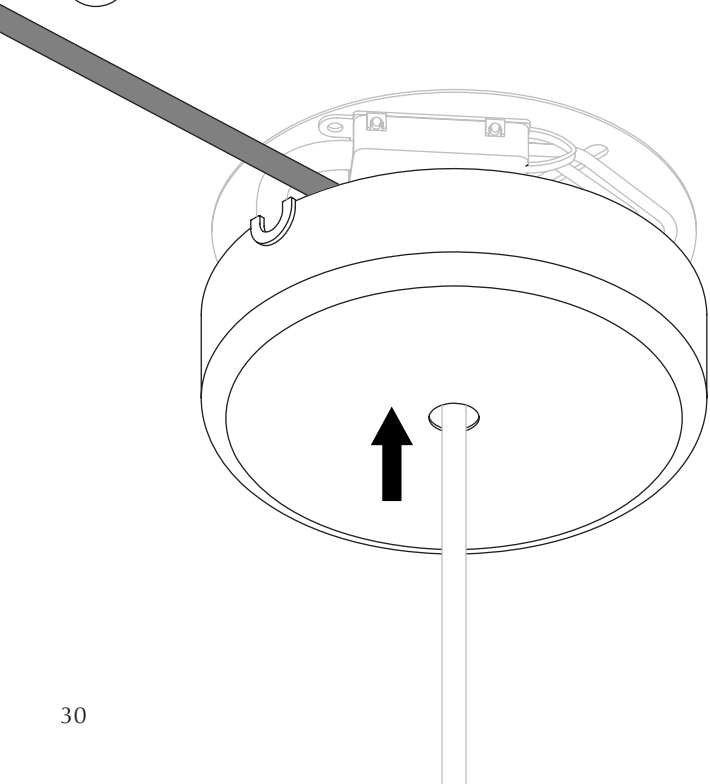

A.8

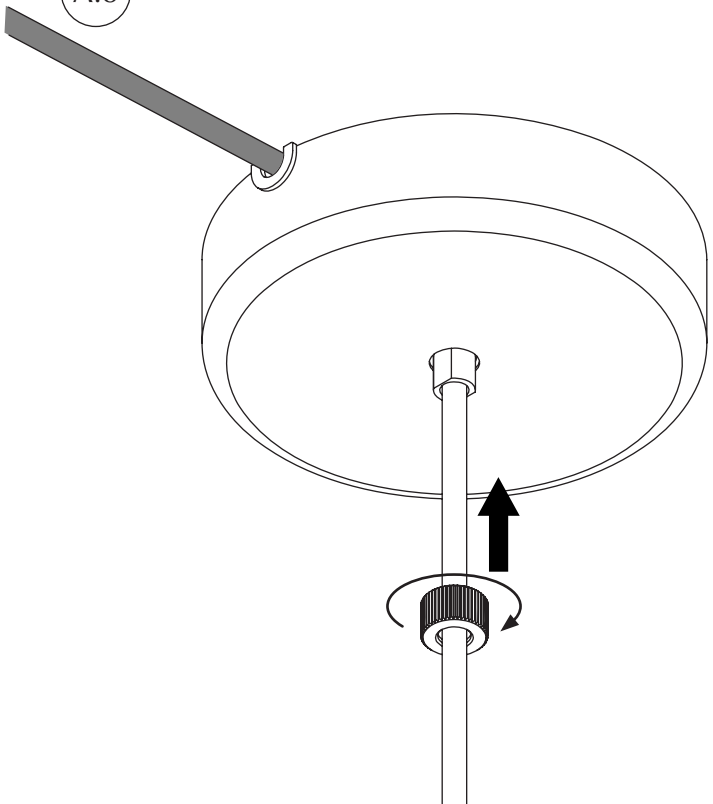

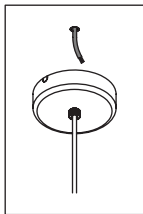

B.1

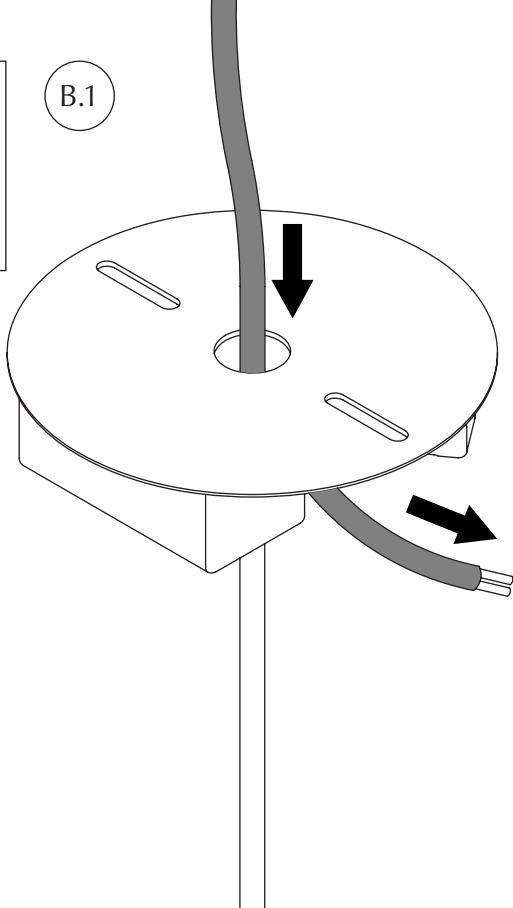



B.2

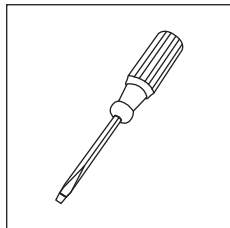
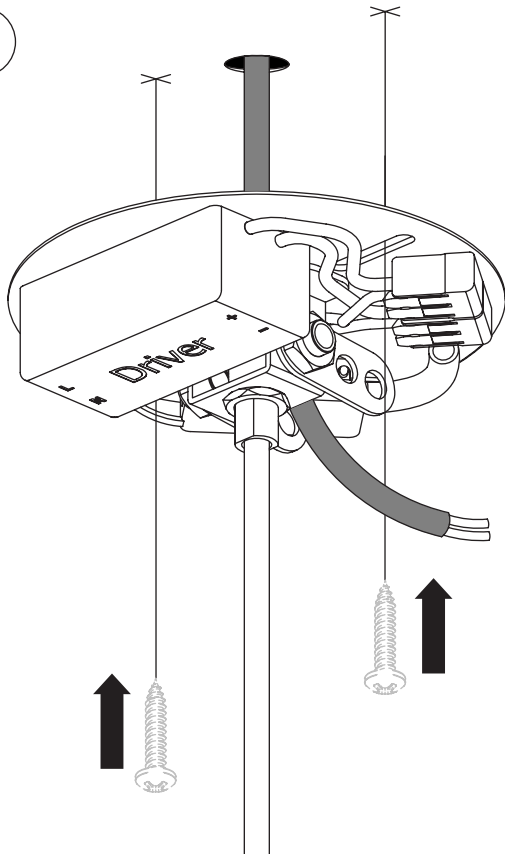

B.3

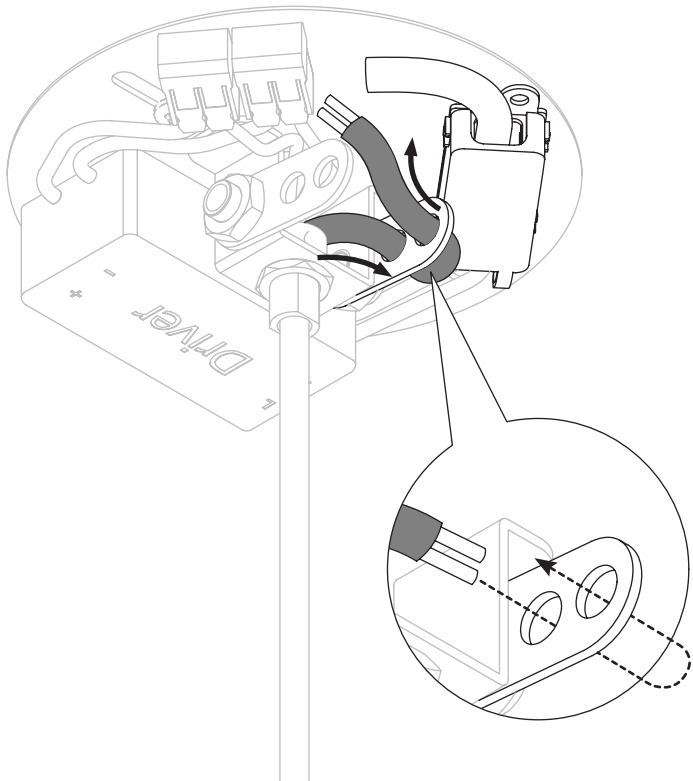

B.4

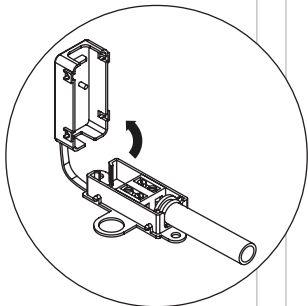
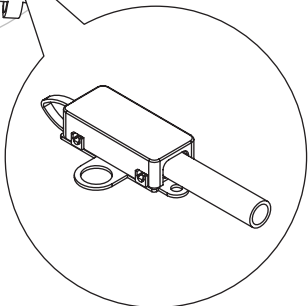
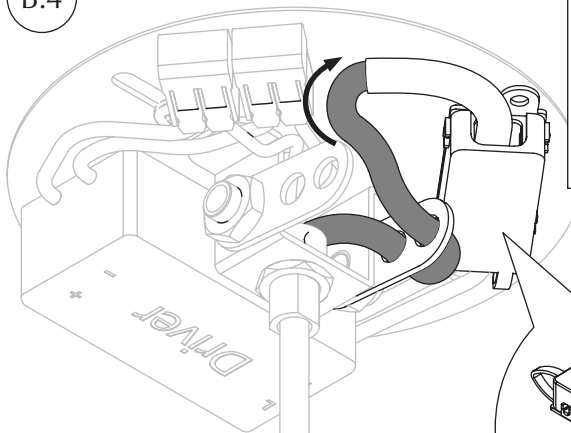
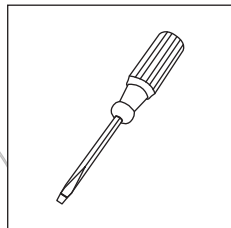

B.5

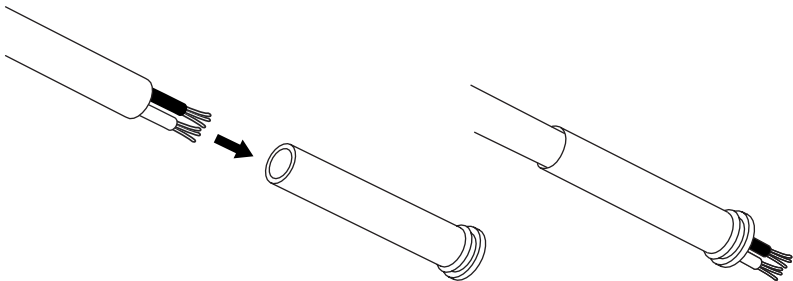

B.6

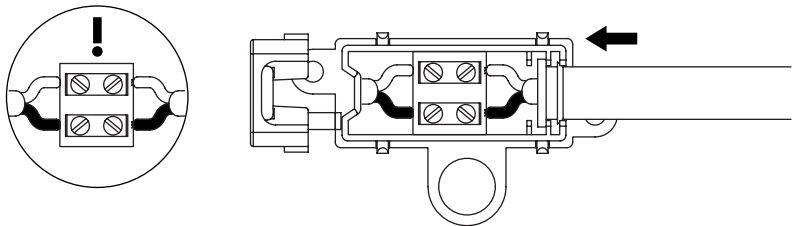

B.7

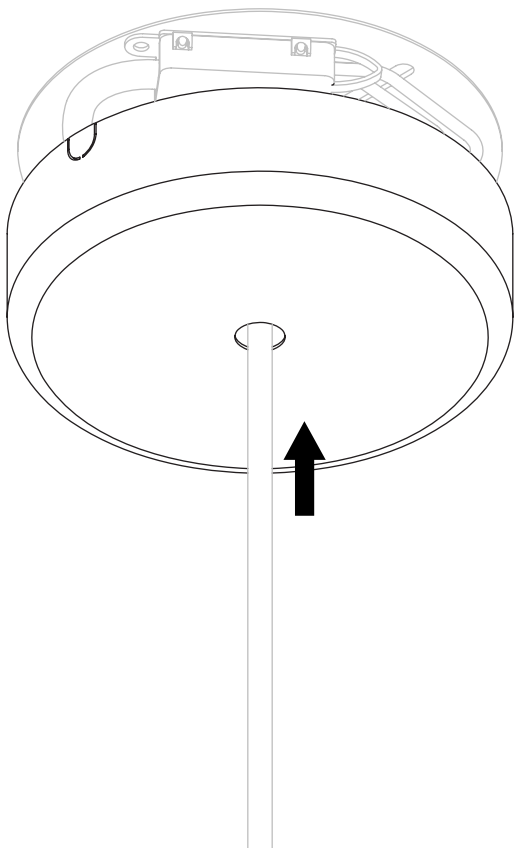

B.8

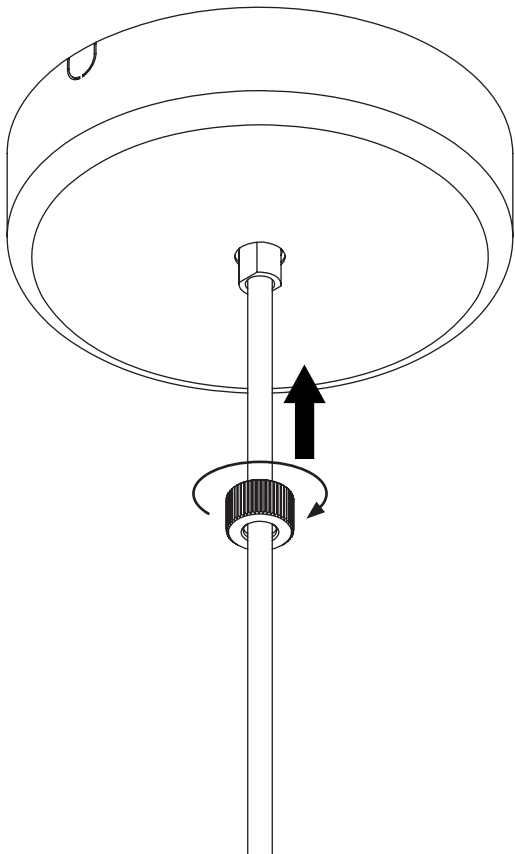

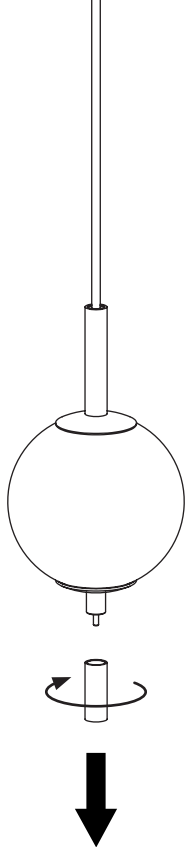

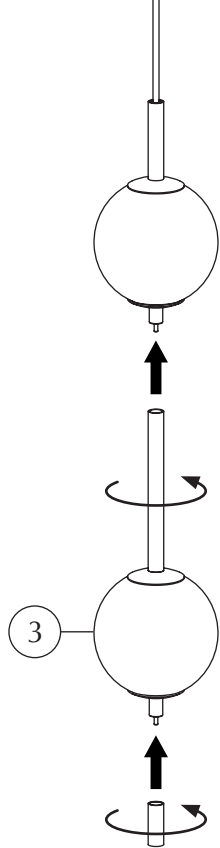



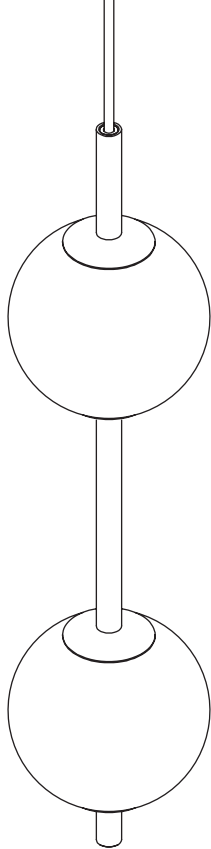

# HOW TO REMOVE / REPLACE SEPARATE CONTROL GEAR

Only use control gear from UIMAGE

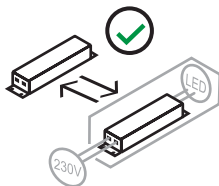

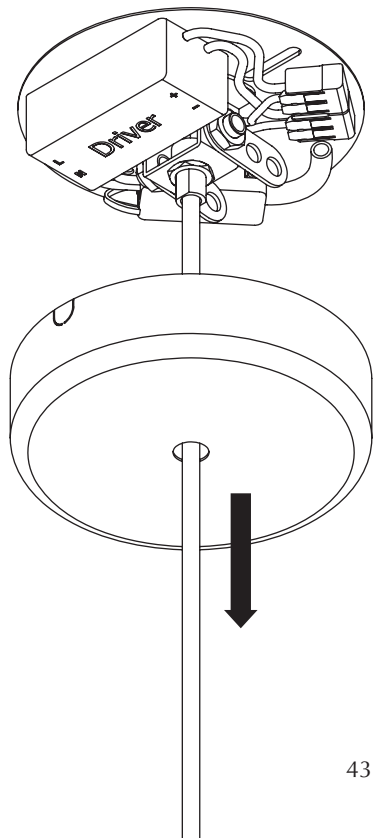
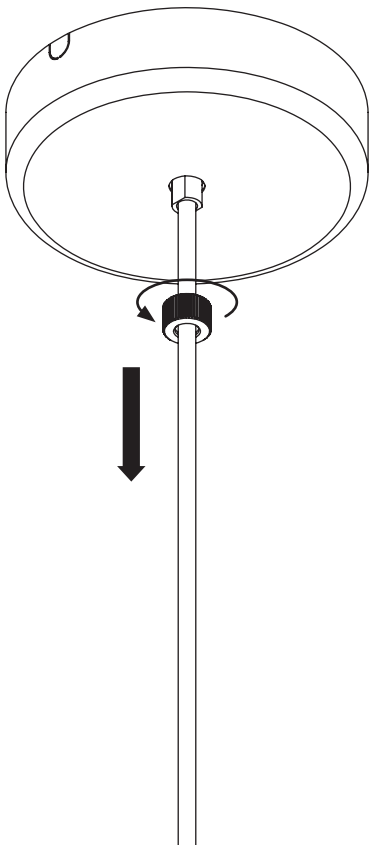

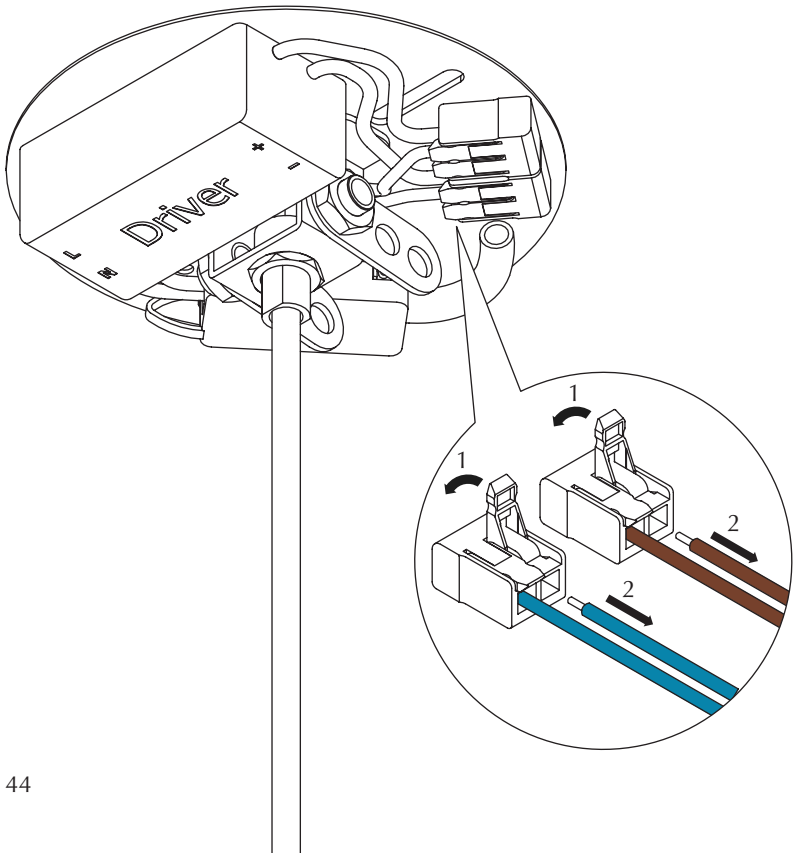

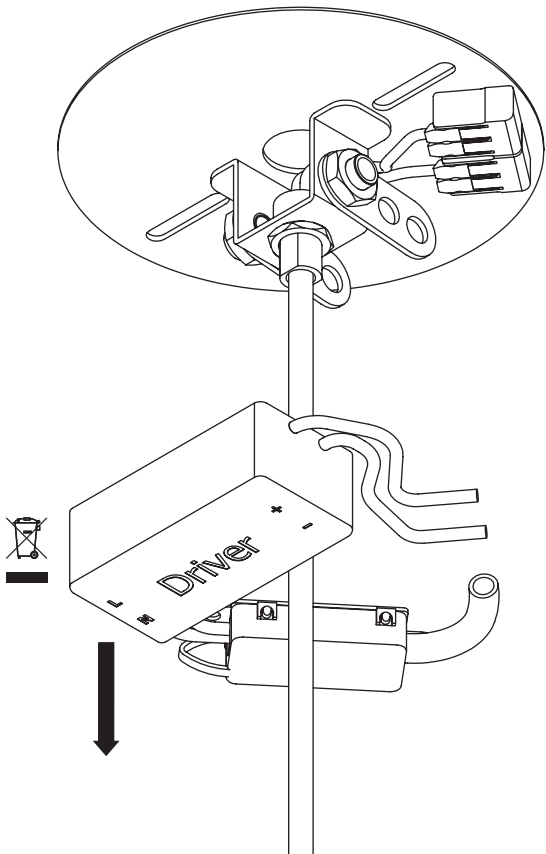

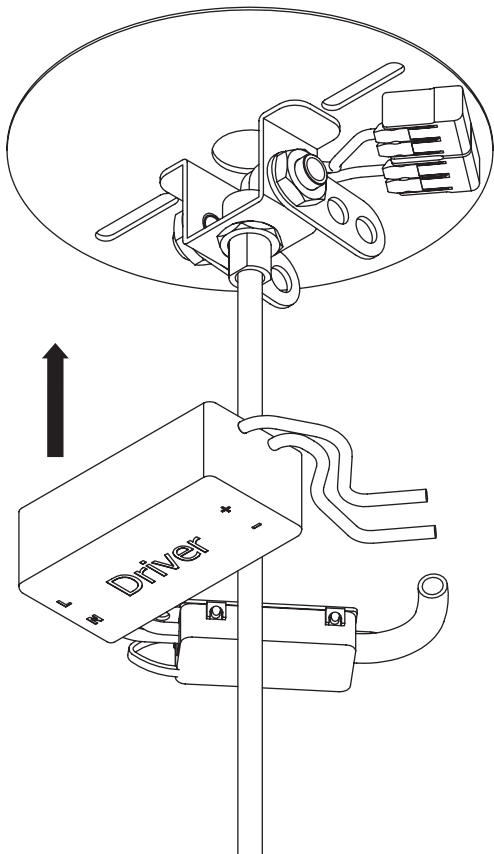

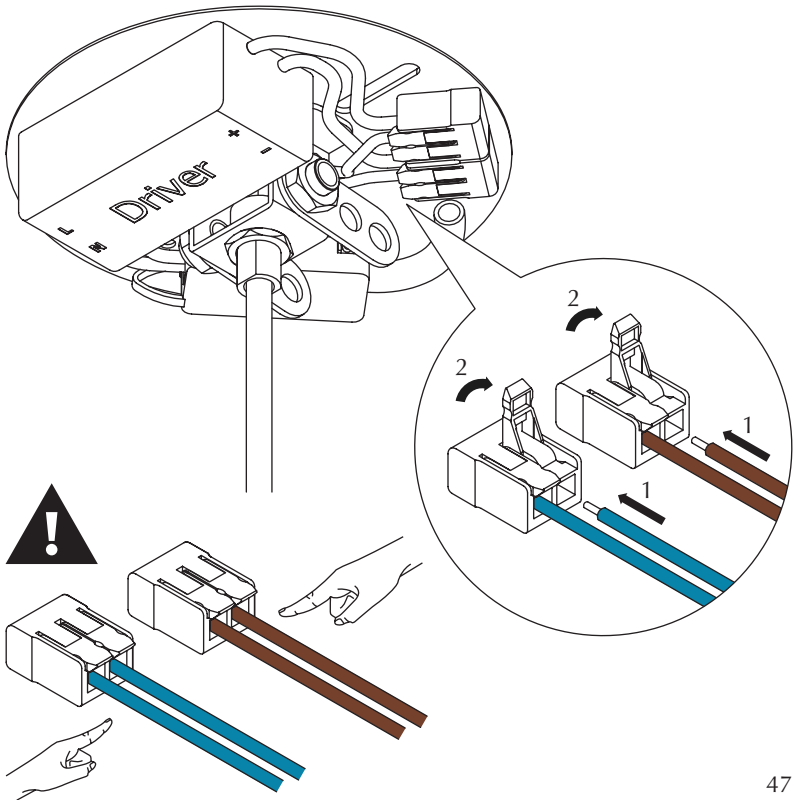

# HOW TO REMOVE LIGHT-SOURCE AT END-OF-LIFE

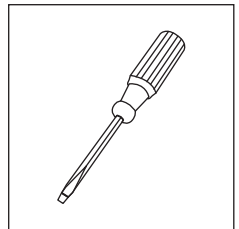
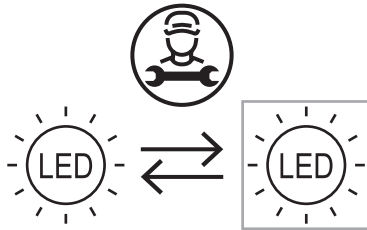



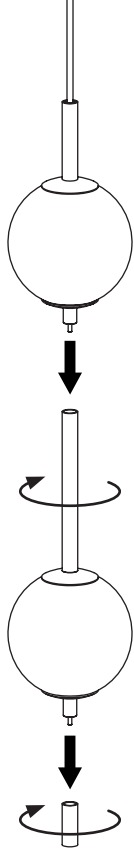

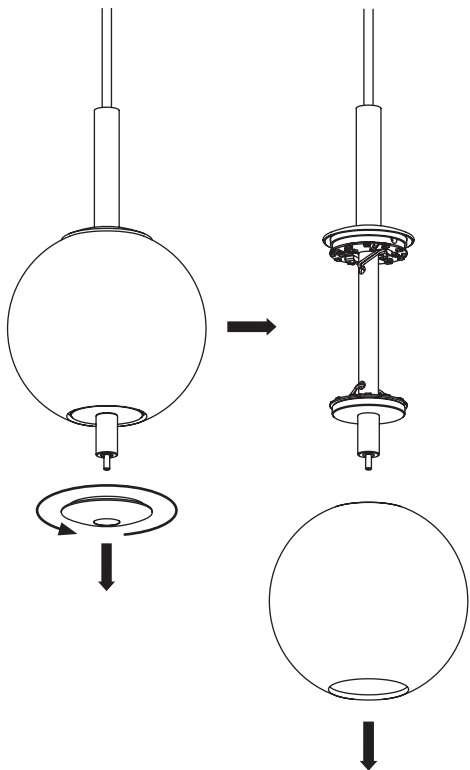
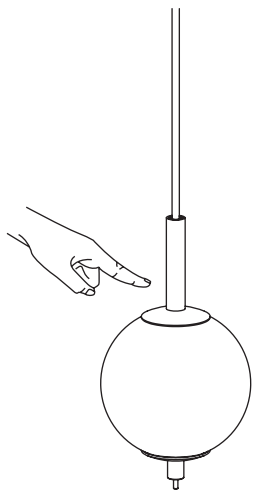

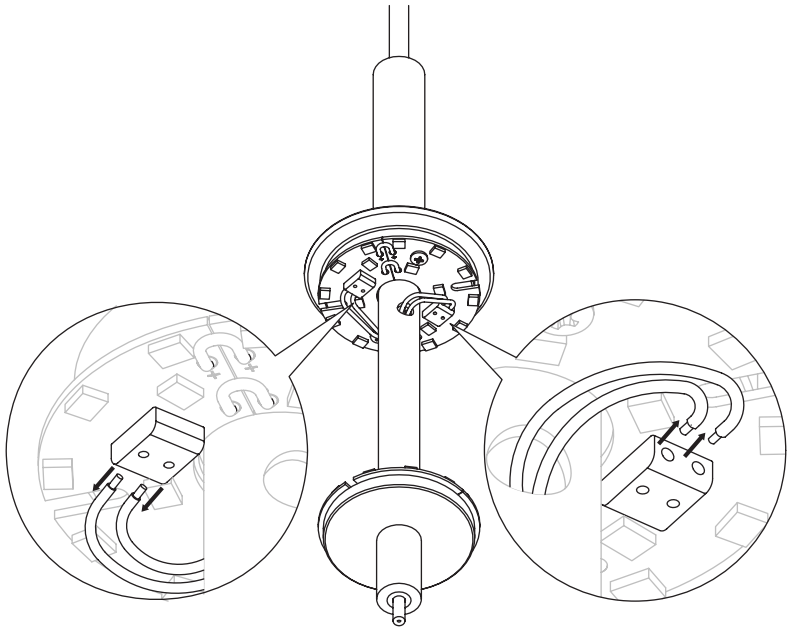

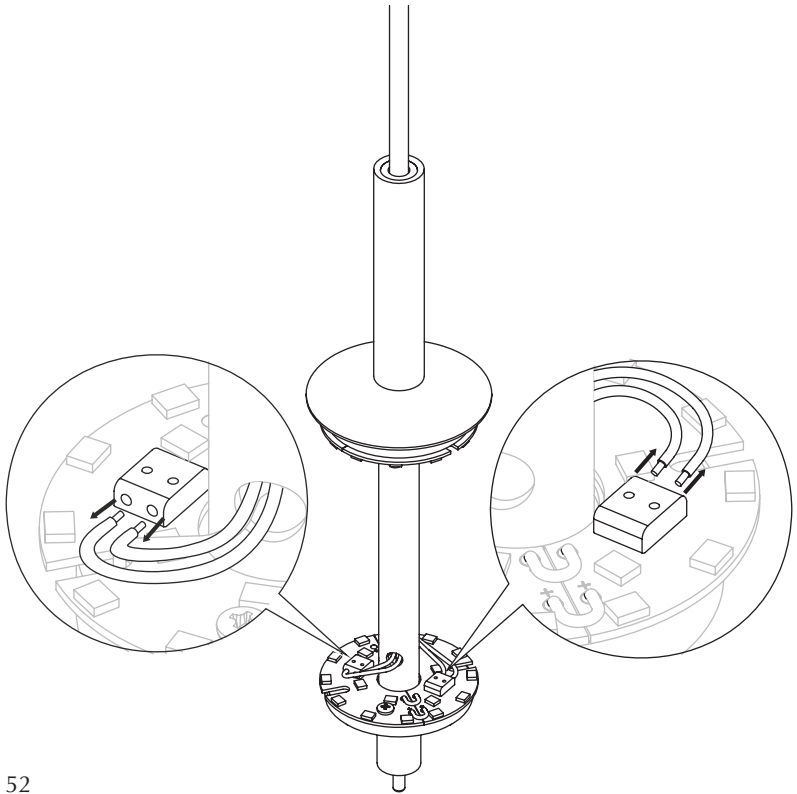

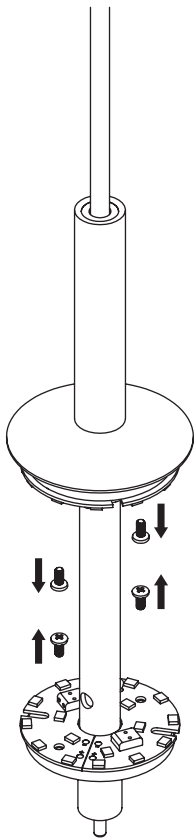
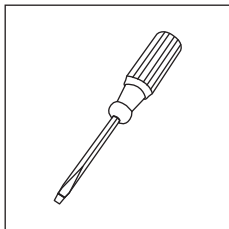

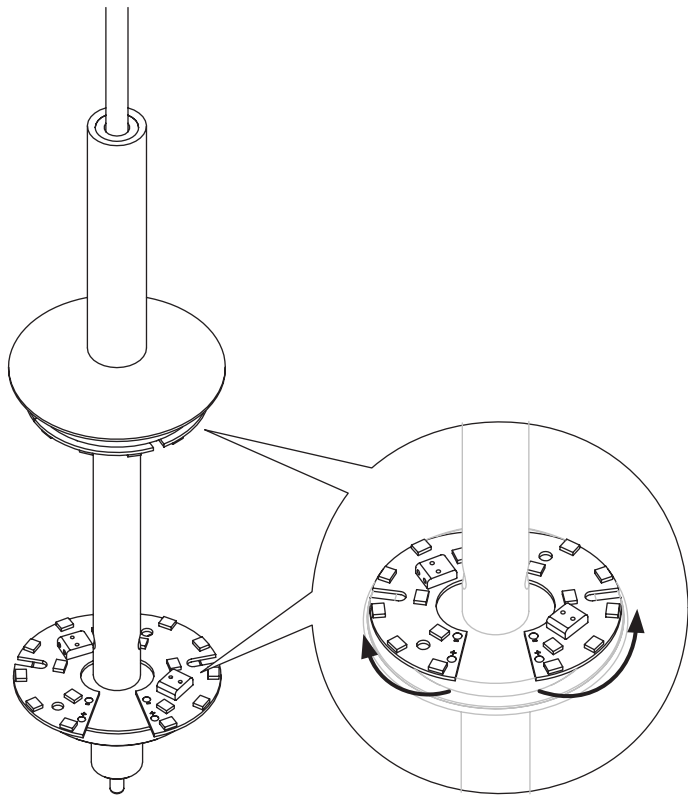

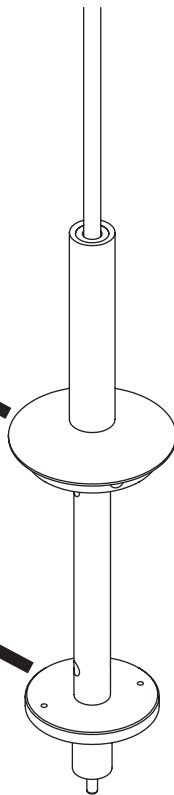
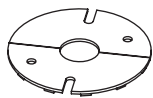

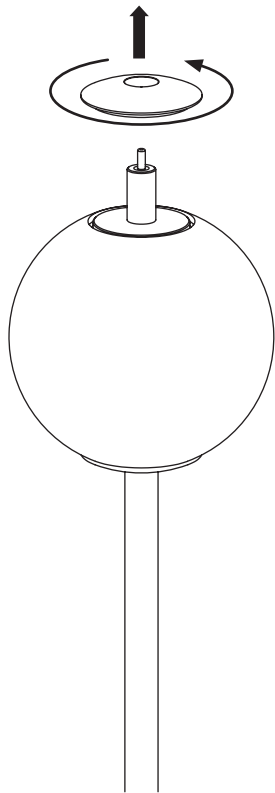
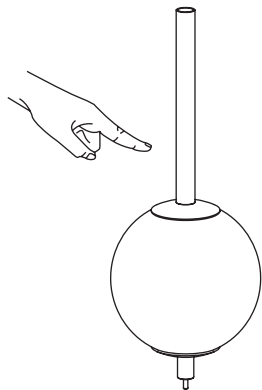



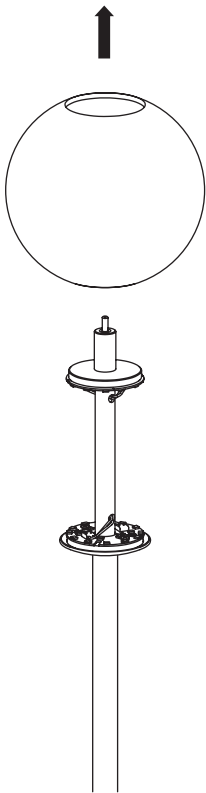

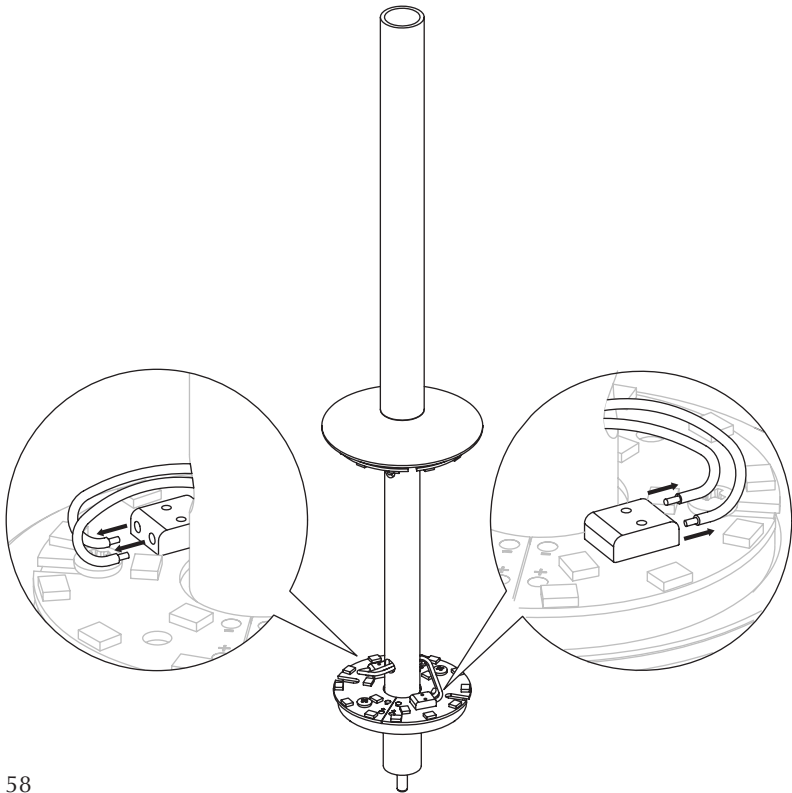

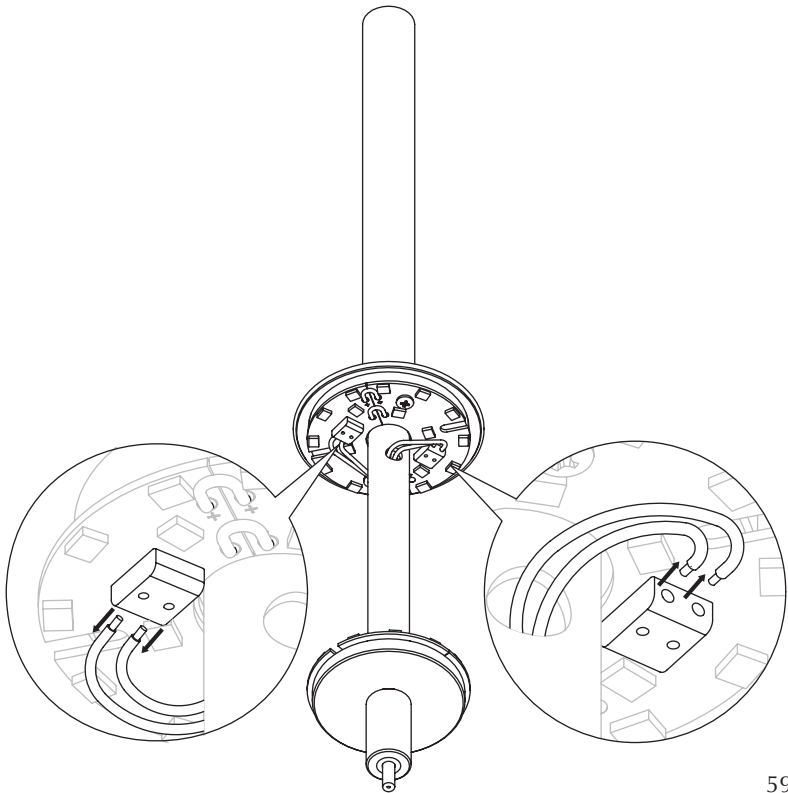

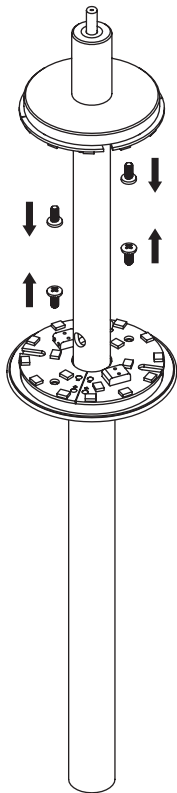
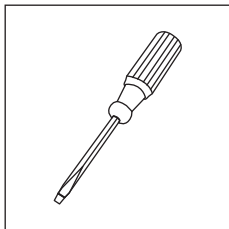

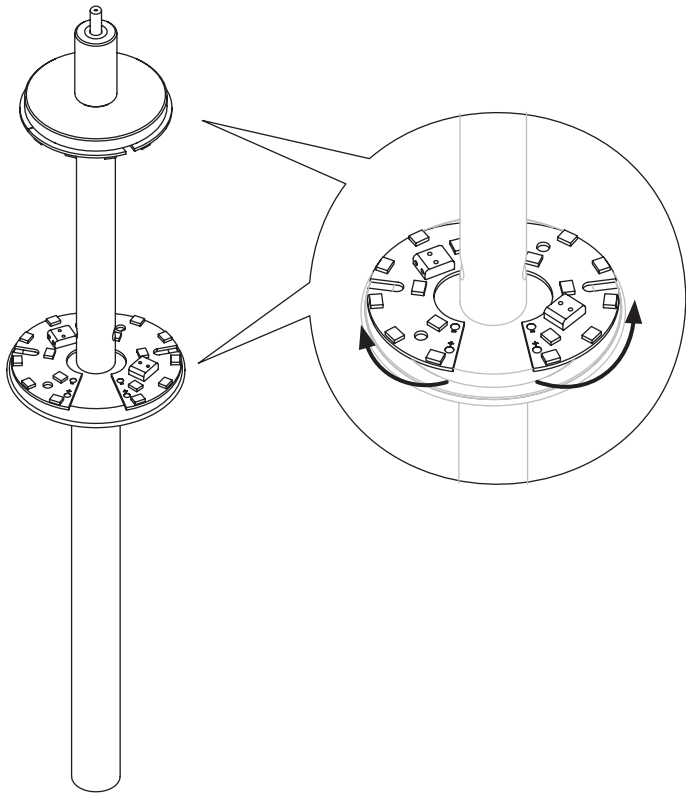

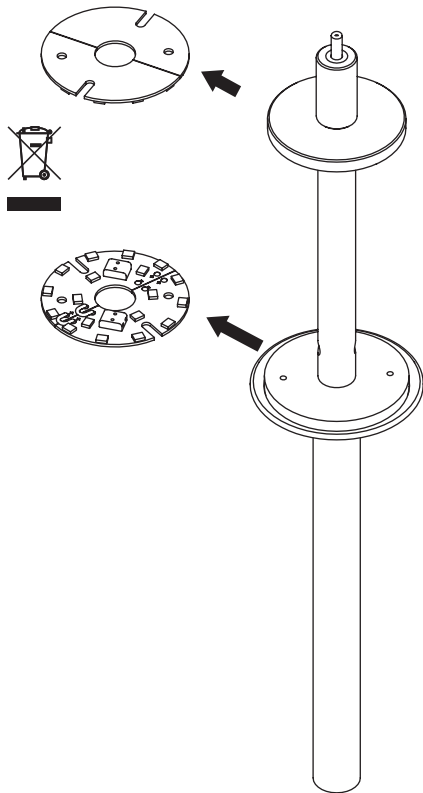



SANTÉ WALL brushed brass  
AROUND THE WORLD mini





**DUENDE** oak  
**ASTERIA MOVE** polished steel



## SUSTAINABLE SUSTAINABILITY EFFORTS

We are dedicated being sensible frontrunners on the environmental responsibility. If we provide timeless and functional quality designs that last, we know nature will prevail, as will UIMAGE.

*"SAVING THE SCENT OF THE FOREST  
AFTER AN EARLY MORNING RAIN"*

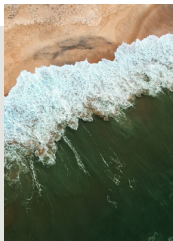

### GIVING BACK TO NATURE

In collaboration with the NGO One Tree Planted, we are planting a tree every time one of our designs made from wood\* are being sold.

\*Includes: The Reader collection, A Conversation Piece collection, Stories collection, Treasures collection, Step It Up collection, Lounge Around collection, Lounge Around Shuffle collection, Audacious collection, Comfort Circle collection, Hang Out collection, My Spot collection, One More Look collection, Flow collection, Clava Wood collection, Forget Me Not collection, Chimes collection, Jazz collection, Heart'n'Soul collection, Italic collection, The Socialite collection, Butterflies collection, Curious collection, Komorebi collection, Together collection

## MULTIFUNCTION AND FLEXIBILITY

One of the key aspects of the designs at UIMAGE is multiple functions and flexibility. Designing with more than one function in mind is a sustainable mindset as it reduces the number of products you need to buy to get a complete setting for your space.



## RECYCLING

Please follow the marked icons on the packaging materials for correct disposal of the remaining packaging materials:



CARDBOARD



PAPER



Recycle your waste correctly by searching for these icons on the packaging

FOLLOW US ON SOCIAL MEDIA



@umagedesign | #umagedesign | [umage.com](http://umage.com)



240625